

DETAIL A

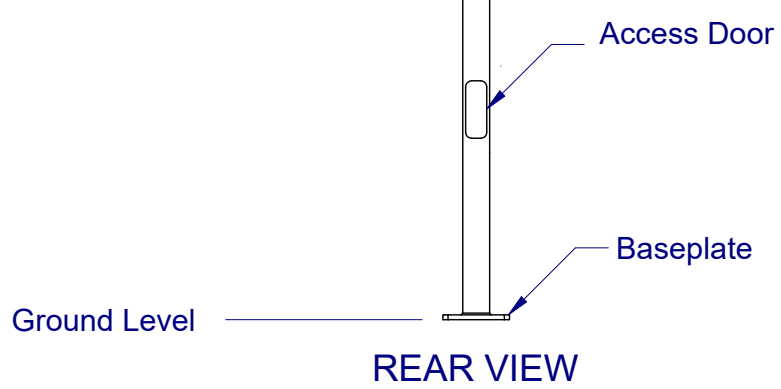

Notes

- 1. All dimensions shown are in mm.
- 2. Column design to comply with AS 1170 & as1798.
- 3. All welding to comply with AS 1554.
- 4. Galvanizing to conform to AS/NZS 4680.
- 5. Paint finish to AS 3887 category long term.

VICPOLE
 STREETSCAPE SOLUTIONS
 62 Jersey Road
 Bayswater Vic 3153